



DELTA SINGLE CARTRIDGE SEAL FOR HEAVY DUTY/ HIGH PRESSURE APPLICATIONS

Rugged heavy duty design to accommodate demanding applications on large equipment.

STYLE 30HD



Technical Features

Deltas' cool running gland design provides clearances 10 times greater than the average clearance provided by other seal manufacturers' designs. This feature maximizes the volume of flow around seal faces, resulting in a cooler, cleaner face environment, providing extended seal life.

Tangential flush connections positioned over the seal faces utilize the largest thru hole diameter available, supplying over 4 times the volume of straight drilled flush holes, providing maximum cooling and cleaning of seal faces maximizing seal life.

Two piece face design is standard to assure optimum seal performance for the most challenging, demanding environments where one piece face construction is vulnerable to premature failure.

Rugged, heavy-duty gland castings eliminate distortion related failures typically encountered on "low cost, light duty gland designs".

Rotary inboard faces stabilized under compression are flexibly mounted utilizing o-rings for their shock and vibration absorption qualities. This eliminates premature fractures in the faces under thermal and mechanical shock that can cause catastrophic failures in other designs with faces under tension.

Balanced stationary cartridge design utilizes all static o-rings, which eliminates damage to the pump shaft/sleeve or seal normally caused by rotary pusher component or pusher cartridge type seals, allowing use of solid pump shafts that minimize deflection.

Positive hold, metal-centering clips center the seal in both the axial and radial directions.

Optional features:

- Quench and drain feature

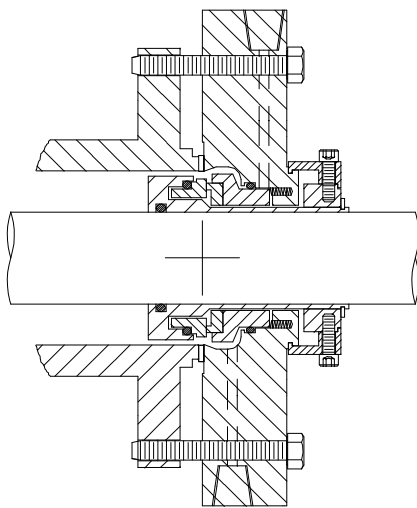

Choose from spare parts kits for field repair or the optional factory repair program. State of the art, easy-to-install design uses the least number of components, simplifying field repair, resulting in low life cycle costs.

All seals are pressure tested at the factory assuring 100% sealability during startup.

Application Data

Shaft speed: To 3600 RPM

Pressure: Vacuum to 400 PSI

Temperature: See O-ring limitations

Materials

Metal Parts: 316SS

Springs: Hastelloy "C"

Faces: Combinations of Carbon, Sintered-Silicon Carbide, and Tungsten Carbide

Elastomers: Viton, EPR, Kalrez, Aflas Teflon

DIMENSIONAL DATA FOR DELTA SEAL STYLE 30HD

FRONT VIEW

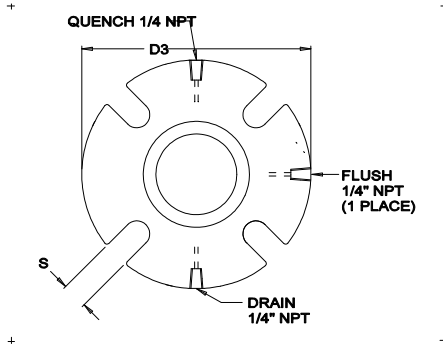

SIDE VIEW

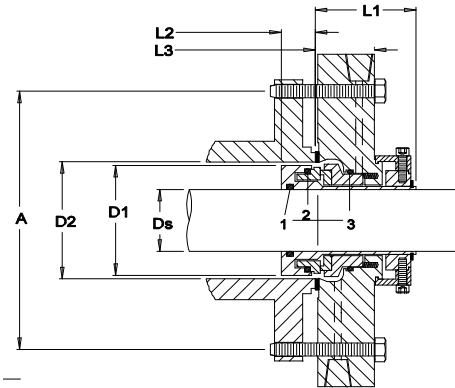

OPTIONAL GLAND FEATURE

Quench and Drain optional on this seal model.

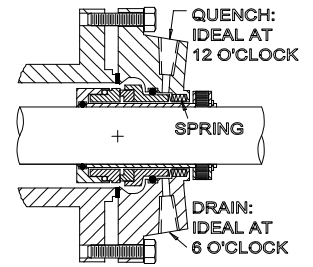

(REPRESENTATIVE VIEW)

DS Seal Size	D1 Sleeve OD	D2 Min	D2 Max	D3 Gland OD	D4 Gland Flat	A				S Slot Width	L1 Outside Length	L2 Inside Length	L3 Gland Length	Pos. 1 Oring	Pos. 2 Oring	Pos. 3 Oring	Pos. 4 Oring	Pos. 5 Oring	Pos. 6 Oring
						Min. Bolt Circle by Stud Size													
						3/8"	1/2"	5/8"	3/4"										
4.000	5.160	5.310	5.850	9.000	N/A	6.900	7.025	7.150	8.100	2.360	0.890	1.370	242	250	250				
4.250	5.410	5.560	6.100	9.500	N/A	7.150	7.275	7.400	8.100	2.360	0.890	1.370	244	252	252				
4.500	5.660	5.810	6.350	10.000	N/A	7.400	7.525	7.650	8.100	2.360	0.890	1.370	246	254	254				
4.750	5.610	6.060	6.600	10.500	N/A	7.650	7.775	7.900	8.100	2.360	0.890	1.370	248	256	256				
5.000	6.160	6.310	6.850	11.000	N/A	7.900	8.025	8.150	8.100	2.360	0.890	1.370	250	258	258				
5.250	6.410	6.560	7.100	11.50	N/A	8.150	8.275	8.400	8.100	2.360	0.890	1.370	252	259	259				
5.500	6.660	6.810	7.350	11.50	N/A	8.400	8.525	8.650	8.100	2.360	0.890	1.370	254	260	260				
5.750	6.910	7.060	7.600	12.000	N/A	8.650	8.775	8.900	8.100	2.360	0.890	1.370	256	261	261				
6.000	7.160	7.310	7.850	12.000	N/A	8.900	9.025	9.150	8.100	2.360	0.890	1.370	258	262	262				
6.250	7.410	7.560	8.100	12.000	N/A	9.150	9.275	9.400	8.100	2.360	0.890	1.370	259	263	263				
6.500	7.660	7.810	8.350	12.000	N/A	9.400	9.525	9.650	8.100	2.360	0.890	1.370	260	264	264				
6.750	7.910	8.060	8.600	12.50	N/A	9.650	9.775	9.900	8.100	2.360	0.890	1.370	261	265	265				
7.000	8.160	8.310	8.850	14.000	N/A	9.900	10.025	10.150	8.100	2.360	0.890	1.370	262	266	266				
7.250	8.410	8.560	9.100	14.000	N/A	10.150	10.275	10.400	8.100	2.360	0.890	1.370	263	267	267				
7.500	8.660	8.810	9.350	14.500	N/A	10.400	10.525	10.650	8.100	2.360	0.890	1.370	264	268	268				
7.750	8.910	9.060	9.600	15.000	N/A	10.650	10.775	10.900	8.100	2.360	0.890	1.370	265	269	269				
8.000	9.160	9.310	9.850	15.000	N/A	10.900	11.025	11.150	8.100	2.360	0.890	1.370	266	270	270				
8.250	9.410	9.560	10.100	15.500	N/A	11.150	11.275	11.400	8.100	2.360	0.890	1.370	267	271	271				
8.500	9.662	9.810	10.350	16.000	N/A	11.400	11.525	11.650	8.100	2.360	0.890	1.370	268	272	272				

Distributed By:

(Phone)
(Fax)



Manufactured By:

Delta
44 Propper Lane
Fall River, MA 02720
508-324-4032 (Phone)
508-324-4339 (Fax)

