

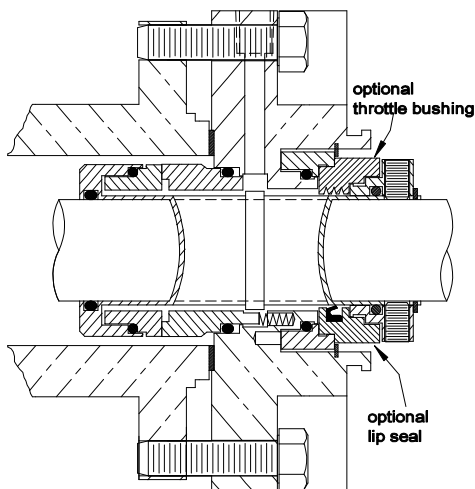

## DELTA SINGLE CARTRIDGE DESIGN FOR SEVERE SERVICE APPLICATIONS

Optional floating throttle bushing or lip seal design accommodates fluids with dissolved and undissolved solids. Provides solutions for thermal setting products, crystallization, and slurry applications.

### STYLE 8000

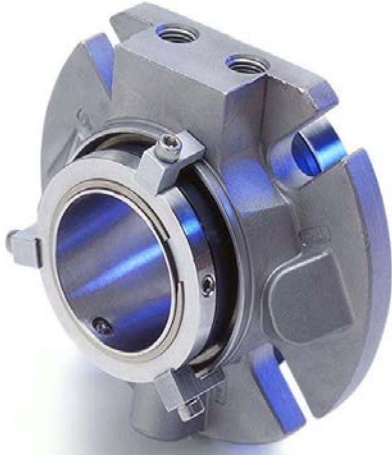

### Technical Features

**Delta's integral throttle bushing or lip seal** provides a quench on the atmospheric side of seal to prevent buildup of particles carried by normal seal weepage of product which may cause hang-up of springs and seal faces. The 8000 series offers a cost-effective alternative as a replacement to using compression packing, double mechanical seals with auxiliary systems, and dynamically sealed or magnetic drive pumps.

**Optional gland lip seal** provides a secondary containment seal allowing the use of a quench fluid reservoir, stand pipe, or external water flush for outboard side lubrication of seal faces. This configuration offers reduced maintenance and plant water consumption in demanding applications in power, pulp and paper, and chemical processing industries.

**Self-venting, bi-directional barrier/quench fluid connections** accommodate shaft rotations in either direction on horizontal and vertically mounted equipment.

**Interchangeable stationary faces enable application customization**, accommodating the widest range of operating conditions and applications in industry. Monolithic, one-piece designs provide unequalled face stability under fluctuating system operating conditions. Two piece face designs that assure optimum seal performance for the most challenging, demanding environments where one piece face construction is vulnerable to premature failure.

**All static o-rings** are used throughout, which eliminates damage to the pump shaft/sleeve or seal normally caused by rotary pusher component or pusher cartridge type seals, allowing use of solid pump shafts that minimize deflection.

**Optional special metal insert** provides a cost effective alternative for corrosive service. This design variation uses a special metal insert (Titanium, Hastelloy "B", "C") for the process wetted surface in a standard 316 SS gland.

**Rotary inboard faces stabilized under compression** are flexibly mounted utilizing o-rings for their shock and vibration absorption qualities. This eliminates premature fractures in the faces under thermal and mechanical shock that can cause catastrophic failures in other designs with faces under tension.

### Application Data

**Shaft speed:** To 3600 RPM

**Pressure:** Vacuum to 400 PSI

**Temperature:** See O-ring limitations

### Materials

**Metal Parts:** 316SS, Alloy 20, Hastelloy "C", Titanium

**Springs:** Hastelloy "C"

**Faces:** Combinations of Carbon, Sintered-Silicon Carbide, and Tungsten Carbide

**Elastomers:** Viton, EPR, Kalrez, Aflas, Teflon

**Positive hold, metal centering clips** center the seal in both the axial and radial directions.

**Stationary springs are mounted in the gland** and are completely isolated from the pumped product and are not susceptible to centrifugal force during operation so coil fatigue of the springs is prevented.

Choose from spare parts kits for field repair or the optional factory repair.

### Optional Features:

- 2 piece stationary face

- Exotic Metal Gland insert design

Select one of the following:

- Floating Throttle Bushing design (Bronze or Carbon)

- Lip Seal Design

# DIMENSIONAL DATA FOR DELTA SEAL STYLE 8000

## FRONT VIEW

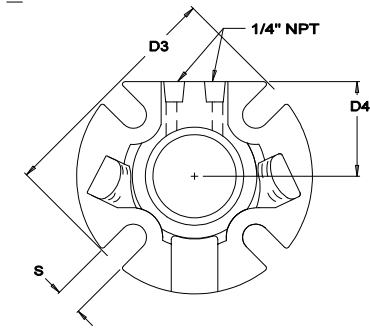

## SIDE VIEW

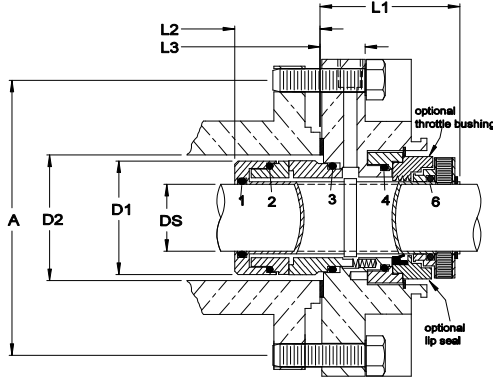

## OPTIONAL GLAND FEATURE

Optional exotic metal gland insert for corrosive environments.  
(Hastelloy "C", "B", Titanium, etc.)

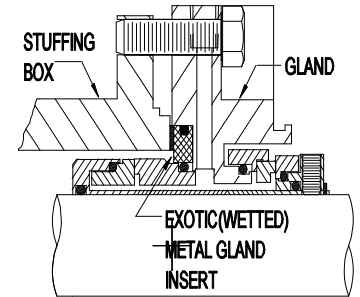

DS Seal Size	D1 Sleeve OD	D2 Min	D2 Max	D3 Gland OD	D4 Gland Flat	A				S Slot Width	L1 Outside Length	L2 Inside Length	L3 Gland Length	Pos. 1 Oring	Pos. 2 Oring	Pos. 3 Oring	Pos. 4 Oring	Pos. 5 Oring	Pos. 6 Oring
						Min. Bolt Circle by Stud Size													
						3/8"	1/2"	5/8"	3/4"										
0.937	1.685	1.740	2.025	4.090	1.908	2.875	3.020	3.207	3.457	0.460	2.130	1.275	0.570	120	127	127	126		122
1.000	1.685	1.740	2.025	4.090	1.908	2.875	3.020	3.207	3.457	0.460	2.130	1.275	0.570	120	127	127	126		122
1.125	1.810	1.865	2.200	4.095	1.908	2.875	3.025	3.212	3.462	0.460	2.130	1.275	0.570	122	129	129	128		124
1.250	1.960	2.000	2.250	4.405	2.046	3.135	3.260	3.447	3.697	0.460	2.130	1.275	0.570	124	131	131	130		126
1.375	2.085	2.125	2.410	4.410	2.046	3.140	3.265	3.452	3.702	0.460	2.130	1.275	0.570	126	133	133	132		128
1.437	2.205	2.245	2.550	4.810	2.065	3.355	3.480	3.667	3.917	0.530	2.130	1.275	1.250	128	135	135	134		130
1.500	2.205	2.245	2.550	4.810	2.065	3.355	3.480	3.667	3.917	0.530	2.130	1.275	1.250	128	135	135	134		130
1.625	2.345	2.375	2.700	4.815	2.065	3.360	3.485	3.672	3.922	0.530	2.130	1.275	1.250	130	137	137	136		132
1.750	2.460	2.500	2.850	5.440	2.305	3.565	3.690	3.877	4.127	0.560	2.130	1.275	0.570	132	139	139	138		134
1.875	2.580	2.620	2.915	5.445	2.305	3.570	3.695	3.882	4.132	0.560	2.130	1.275	0.570	134	141	141	140		136
1.937	2.715	2.750	3.110	5.500	2.450	3.780	3.905	4.092	4.342	0.560	2.130	1.275	0.570	136	143	143	142		138
2.000	2.715	2.750	3.110	5.500	2.450	3.780	3.905	4.092	4.342	0.560	2.130	1.275	0.570	136	143	143	142		138
2.125	2.835	2.875	3.125	5.840	2.450	3.785	3.910	4.097	4.347	0.560	2.130	1.275	0.570	138	145	145	144		140
2.250	2.960	3.000	3.580	6.170	2.460	4.310	4.435	4.622	4.872	0.640	2.130	1.275	1.250	140	147	147	146		142
2.375	3.090	3.125	3.655	6.175	2.460	4.315	4.440	4.627	4.877	0.640	2.130	1.275	1.250	142	149	149	148		144
2.437	3.215	3.250	3.820	6.420	2.742	4.515	4.640	4.827	5.077	0.640	2.130	1.275	0.570	144	151	151	150		146
2.500	3.215	3.250	3.820	6.420	2.742	4.515	4.640	4.827	5.077	0.640	2.130	1.275	0.570	144	151	151	150		146
2.625	3.340	3.375	3.735	6.425	2.742	4.520	4.645	4.832	5.082	0.640	2.130	1.275	0.570	146	151	151	151		148
2.750	3.660	3.700	4.030	7.755	3.020	5.065	5.190	5.377	5.627	0.700	2.300	1.160	1.250	232	236	236	236		233
3.000	3.915	3.955	4.315	7.760	3.020	5.070	5.195	5.382	5.632	0.700	2.300	1.160	1.250	234	238	238	238		235
3.250	4.165	4.205	4.925	8.495	3.331	5.812	5.937	6.124	6.374	0.780	2.300	1.160	1.250	236	240	240	240		237
3.500	4.415	4.455	5.025	8.500	3.331	5.817	5.942	6.129	6.379	0.780	2.300	1.160	1.250	238	242	242	242		239
3.750	4.660	4.700	5.032	8.505	3.331	5.822	5.947	6.134	6.384	0.780	2.300	1.160	1.250	240	244	244	244		241
4.000	4.915	4.955	5.875	9.645	3.750	7.005	7.130	7.317	7.567	0.780	2.300	1.160	1.250	242	246	246	246		243
4.250	5.165	5.205	6.125	9.650	3.750	7.010	7.135	7.322	7.572	0.780	2.300	1.160	1.250	244	248	248	248		245
4.500	5.415	5.455	6.125	9.655	3.750	7.015	7.140	7.327	7.577	0.780	2.300	1.160	1.250	246	250	250	250		247
4.750	5.665	5.705	6.225	9.660	3.750	7.020	7.145	7.332	7.582	0.780	2.300	1.160	1.250	248	252	252	252		249

Distributed By:

(Phone)  
(Fax)



Manufactured By:

Delta  
44 Propper Lane  
Fall River, MA 02720  
508-324-4032 (Phone)  
508-324-4339 (Fax)

