

DELTA O-RING CARTRIDGE SEAL ASSEMBLY AND INSTALLATION INSTRUCTIONS



INTRODUCTION:

These instructions are provided to familiarize the user with the seal and its use. The instructions must be read carefully and applied whenever work is done on the seal. Please keep available for future reference.

IMPORTANT: These instructions are for the installation and operation of a seal as used in rotating equipment and will help to avoid danger and improve reliability. The information required may change with other types of equipment or installations. These instructions must be read in conjunction with the instruction manuals for both the pump and any auxiliary equipment.

If the seal is to be used for an application other than that originally intended or outside the recommended performance limits, Delta must be contacted before its installation and use.

Any warranty may be affected by improper handling, installation, or use of this seal. Contact the company for information as to product warranty and limitations of liability.

If questions or problems arise, contact your local Delta Sales/Service Engineer or the original equipment manufacturer, as needed.

IMPORTANT: Delta Mechanical Seals are precision products and must be handled appropriately. Take particular care to avoid damage to lapped sealing faces.

SAFETY NOTES:

1. The following designations are used in the installation instructions to highlight areas of particular importance:

NOTE: Refers to special information on how to install or operate the seal.

IMPORTANT: Refers to special information towards the prevention of damage to the seal or its surroundings.

WARNING: Refers to mandatory instructions designed to prevent personal injury or extensive damage.

- Installation, removal and maintenance of the seal must be carried out only by qualified personnel who have read and understood all instructions.
- The seal is designated exclusively for sealing rotating equipment; manufacturer cannot be held liable for use of the seal for purposes other than noted.
- The seal must only be used in perfect conditions and must be operated within the recommended performance limits in accordance with its designated use set out in these instructions for installation of Delta Mechanical Seals.
- If the fluid pumped is hazardous or toxic, special care and appropriate precautions must be taken to ensure that any seal leakage is adequately contained. Further information on sealing hazardous or toxic fluids is available from Delta and should be read carefully prior to seal installation.
- Fluorocarbon components should never be burned or incinerated as the fumes and residues are toxic. If fluorocarbons are accidentally heated above 700 degrees F they decompose, therefore, protective gloves should be worn as acid may be present.
- PTFE should never be burned or incinerated as the fumes are toxic and dangerous.

PRIOR TO STARTING EQUIPMENT:

- Check the pump at the coupling for proper alignment of the motor.
- Ensure that the gland nuts/bolts are securely tightened and that all screws are securely fastened.
- Complete the assembly of the pump and turn the shaft to ensure free rotation prior to startup.
- Consult all equipment operating instructions to check for proper piping and connections, particularly regarding: seal recirculation/flush, heating or cooling requirements, and external services.

IMPORTANT: This mechanical seal is designed to operate in a liquid so the heat created must be removed. The following check should be carried out after seal installation and after any period of equipment inactivity.

- Check that all seal chamber lines are open and free from obstruction and ensure that the seal chamber is properly vented and filled with liquid; refer to "Delta Start-up Procedures" and pump instruction manual.

IMPORTANT: Dry-running, often indicated by a squealing noise from the seal area, causes overheating and damage to the sealing surfaces, resulting in excessive leakage and shortened seal life.

WARNING: Before start-up, make sure all personnel and tools have been moved to a safe distance so there is no contact with rotating components on the pump, coupling, seal and motor.

WARNING: Seal installation should be handled only by qualified, trained personnel. If questions arise, contact the local Delta Engineer. Improper use or installation of this product could result in injury and/or harmful emissions to the environment, and may affect any warranty on the product. Please contact Delta for information as to exclusive product warranty and liability limitations.

AFTER EQUIPMENT HAS RUN:

- Make sure that the pump is electrically isolated.

WARNING: If the seal has been used on toxic or hazardous fluids, ensure that the seal is correctly decontaminated and safe prior to commencing work.

NOTE: Fluid is often trapped during draining and may exist outside the seal. The pump instruction manual should be consulted for any special precautions.

- Ensure that the pump is isolated by the appropriate valves. Check that the fluid is drained and pressure is fully released.
- Make sure work area is safe, secure, and well ventilated.

SEAL MAINTENANCE:

No maintenance of a seal is possible while installed; therefore, it is recommended that a spare seal (to prevent unnecessary downtime) be held in stock to allow immediate replacement of a removed seal.

WARNING: It is the responsibility of the user to ensure that any parts being sent to a third party have appropriate, safe-handling instructions externally attached to the mechanical seal packaging.

DELTA QUALITY ASSURANCE:

This seal has been assembled in accordance with Delta Quality Assurance Standards. With proper maintenance and use, it will give safe and reliable operation to the maximum recommended performance as shown in Delta publications.

DOUBLE CARTRIDGE SEAL ASSEMBLY FOR STYLE 3820



TOOLS REQUIRED: Allen wrench and special lubricant provided with seal or repair kit.
Additional tools: small screwdriver, paper clip or o-ring extractor.

NOTE: Bold type below identifies components listed in "Seal Cutaway/Part Identification Key" on page 4.

DISASSEMBLY:

1. Compress seal slightly and remove **snap ring**.
2. Loosen **set screws** and lift off **lock collar** and **outboard rotary face**.
3. Remove **sleeve** with **inboard rotary face** out of the **gland**.
4. Carefully remove the **inboard rotary face** from the **sleeve**.
5. Carefully remove the **inboard stationary face** from the **gland**. Do not damage seal faces.
6. Carefully remove inboard **o-rings** from **position 1, position 2, and position 3**.
7. On seal model supplied with optional "**Exotic Metal Gland Insert**" (typically of Hastelloy "C", "B" or Titanium) remove insert and o-rings.
8. Remove the inboard **springs** from the **gland**.
9. Replace **gasket** (some models use an o-ring in place of a gasket) if required, making sure the **gasket** is centered to **gland** bore. If seal model is supplied with "**Exotic Metal Gland Insert**", replace gasket on gland insert, centering it.
10. Place gland down on table with gasket surface down. Carefully remove **outboard stationary face**.
11. Carefully remove the **o-ring position 4**.
12. Remove all outboard **springs**.
13. Carefully remove the **outboard rotary face** from the **lock collar**.
14. Carefully remove **o-ring position 5 and position 6**.

ASSEMBLY:

15. Lubricate all o-rings with the special lubricant provided.
16. Install the **o-ring position 1** in the **sleeve** I.D.
17. Slide the **o-ring position 2** over the **inboard rotary face**.
18. Slide the **inboard rotary face** onto the **sleeve**, aligning the slot on the **inboard rotary face**, with the drive pin in the **sleeve**. Gently seat the **inboard rotary face** evenly, making sure the pin is engaged in the slot to avoid damaging the face.
19. Place new **springs** in the inboard **spring** holes located in the **gland**, (gasket side). Apply a small amount of special lubricant to the bottom of each **spring** which will help the **springs** stay in their holes during assembly.
20. If seal model was supplied with an optional "**Exotic Metal Gland Insert**" (typically Hastelloy "C", "B" or Titanium), install the o-ring around the insert and install the insert into the gland cavity.
21. Install the **o-ring position 3** over the shoulder, on the back side, of the **inboard stationary face**.
22. Install the **inboard stationary face** into the **gland**.

IMPORTANT: On the surface of the inboard stationary face opposite the lapped surface are four slots. The two smaller square slots should be aligned over the anti-rotation lugs in the gland. The remaining two large slots must be aligned with the drilled thru holes located opposite of the drive lugs in the gland cavity.

NOTE: Some models use an inboard stationary face which has four equally spaced identical slots. The four slots will be 90 degrees apart.

23. Clean both seal faces with denatured alcohol and a lint-free cloth.
24. Carefully slide the **sleeve**, with rotary installed, into the **gland** making sure the **sleeve** does not damage the **inboard stationary face**.
25. Place the seal on the table with the drilled thru holes in sleeve facing upwards.
26. Place new **springs** in the outboard side holes located in the **gland**. Apply a small amount of special lubricant to the bottom of each spring which helps the spring stay in their holes during assembly.
27. Install the **o-ring position 4** over the nose (smallest O.D.) in the gland cavity.
28. Carefully install the **outboard stationary face**.

IMPORTANT: Align the slots on the outside diameter of the outboard stationary face, with the two anti-rotation pins in the gland. Gently seat the outboard stationary face evenly, making sure the pins engage the slots.

29. Install the **o-ring position 6** in the **lock collar** I.D.
30. Install the **o-ring position 5** on nose on **lock collar**.
31. Slide the **outboard rotary face** onto the **lock collar** over the **o-ring position 5**. Align the slots (in the surface opposite the lapped face) with the drive lugs in the **lock collar**. Gently seat the **outboard rotary face** evenly, making sure the drive lugs are engaged in the slots to avoid damaging the face.
32. Clean both **outboard faces** with denatured alcohol and a lint free cloth.
33. Visually align the **lock collar set screws** with the drilled thru holes on the end of the sleeve, then evenly compress the **lock collar / outboard rotary face** assembly until the top of the **lock collar** is below the **snap ring** groove in the **sleeve**. Install the **snap ring**.

NOTE: Make sure the **set screws** do not protrude through the I.D. of the **lock collar** prior to compression.

34. Precisely align the **set screws** with the drilled thru holes in the **sleeve** and engage the **set screws** in the thru holes. Make sure the **set screws** do not protrude into the sleeve I.D. bore but they must engage the thru holes.
35. Install and re-tighten the centering clips. Make sure the clips are shouldered squarely on mating surface or in channel grooves, depending on seal style.
36. Pressure test seal according to Delta Standard QA-1-1076.

THE ASSEMBLY IS NOW COMPLETE

EQUIPMENT PREPARATION / INSTALLATION



SHAFT / SLEEVE EXAMINATION:

1. The shaft finish should be 30 micro inches RMS and feel smooth if you run your fingernail down it axially
2. Make sure the shaft or sleeve diameter is within + .001"/- .002" of nominal.
3. Use a dial indicator to measure the shaft runout in the area where the seal will be installed. (Readings should not exceed .002" TIR per inch or shaft diameter.)
4. Place the dial indicator on the end of the shaft and alternately push and pull the shaft axially to measure end play. End play should not exceed .005" TIR.
5. Protect the sleeve o-ring by lubricating the shaft with a clean silicone based lubricant.
6. A static o-ring (position 1) must seal to the shaft at the shown location. Be sure the shaft is clean and free from scratches within the o-ring area.
7. Remove all burrs and sharp corners, especially in areas where the o-ring has to slide. Cover threads and keyway slots to prevent cutting the o-ring during installation.

STUFFING BOX/SEAL CHAMBER EXAMINATION:

8. Check that the stuffing box/seal chamber is clean with no obstructions.
9. The stuffing box face should be a maximum of 125 micro inches RMS for proper gasket sealing.
10. Attach the dial indicator base to the shaft and rotate both the indicator and shaft while reading the runout of the stuffing box face. Misalignment of the stuffing box face relative to the shaft should not exceed .003" TIR per inch of shaft diameter.
11. Some split case pumps will have a misalignment between halves on the stuffing box face. This surface must be machined flat.

PUMP/DRIVER ALIGNMENT:

12. Check the driver shaft (motor) to equipment shaft (pump) alignment using a dial indicator or precision alignment procedure.

NOTE: If any values in the above steps are found to be out of tolerance, corrective actions must be taken to ensure extended seal life.

INSTALLING THE SEAL:

1. Before starting the installation, read the following instructions carefully.
2. Remove the seal from its packaging, inspect for any damage, and wipe clean.
3. Verify that the metallurgy, faces, and o-rings are compatible with the fluid to be sealed.
4. The equipment should be cleaned and comply with the "Equipment Preparation" procedures.
5. Lubricate the o-ring in the sleeve with the special lubricant provided.
6. The set screws go into the small holes in the sleeve. Do not disengage these screws from the sleeve when positioning the seal. Make sure all screws are engaged in the sleeve but do not protrude into the I.D. bore. Also, when repositioning (ex: impeller adjustment) or removing the seal, make sure the three centering clips and socket head cap screws are seated and tightened securely.
7. If the seal is operating at stuffing box pressures above 250 PSI or if the shaft/sleeve is case hardened, replace the 316SS set screws with hardened steel cup point set screws.
8. The centering clips have been preset at the factory. If for any reason you loosen or remove the centering clip cap screws, re-tighten each cap screw firmly. Make sure the centering clips are shouldered squarely on mating surfaces or in channel grooves etc, depending on seal style.
9. Make sure the gasket is glued and centered to the gland bore.
10. Slide the seal onto the shaft by pushing on either the drive collar for horizontal split case pumps or the seal sleeve for ANSI back pull out pumps. Do not push on the gland! Make sure the set screws are engaged through the seal sleeve thru holes, but do not protrude into the sleeve I.D. bore.
11. Reassemble the pump making necessary shaft alignments and impeller adjustments. The impeller can be reset at any time, as long as the centering clips are securely in place and the seal set screws have been loosened only enough to allow the equipment shaft/sleeve to slide through the seal sleeve while the shaft is being moved.
12. Orient the piping connections per the instructions outlined in the "Gland Front View/Piping Arrangement" and "Piping Details" on page 4. Do not connect piping until after gland bolts/nuts have been tightened!
13. Tighten gland bolts/nuts in an alternate pattern until secure (1/4 turns 180 degrees apart). Make sure flat washers are used, failure to do so may cause the gland to move off center.
14. Perform a visual check after bolting to make sure the centering clips are shouldered squarely on gland mating surface, in channel grooves, etc. The gap between the lock collar and the gland should be uniform 360 degrees. If clips are not shouldered push the seal sleeve towards the gland as this should correct the problem.
15. Tighten lock collar set screws evenly 1/4 turns securing cartridge seal to shaft.
16. Remove socket head cap screws and centering clips and save for future use.
17. It is important to check that the sleeve is centered in the gland. To accomplish this turn the shaft by hand to make sure the seal turns freely. If you hear metal to metal contact within the seal, the seal must be re-centered. Replace the centering clips finger tight, loosen gland bolts/nuts, then tighten clips. Go back and perform steps 13 - 17. If metal to metal contact still exists, check the centering of the stuffing box to the shaft.
18. Piping connections can only be made after the gland bolts/nuts are securely tightened. (Steps 1-17 completed).
19. Make appropriate piping connections to the seal assembly and equipment. See "Gland Front View/Piping Arrangements" and "Piping Details", "Environmental Controls" on page 4.

WARNING: Take all necessary precautions and follow all safety procedures before starting the equipment!

TYPICAL STYLE 3820 SEAL ARRANGEMENT



Seal Cutaway

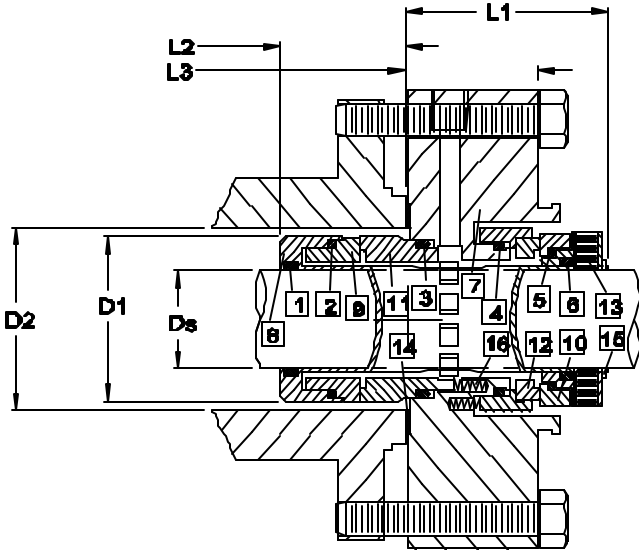

Seal Cutaway/Part Identification Key

Item	Description	Part Number
1	O-ring Pos.1	Standard
2	O-ring Pos.2	Standard
3	O-ring Pos.3	Standard
4	O-ring Pos.4	Standard
5	O-ring Pos.5	Standard
6	O-ring Pos.6	Standard
7	Gland	Standard
8	Sleeve	Standard
9	Inboard Rotary Face:	Standard
10	Outboard Rotary Face:	Standard
11	Inboard Stationary Face:	Standard
12	Outboard Stationary Face:	Standard
13	Set Screws / Lock Collar	Standard
14	Gasket	Standard
15	Snap Ring	Standard
16	Springs	Standard
17	Centering Clips	(Not Shown)
18		
19		
20		

Additional Products

Gland Front View / Piping Arrangement

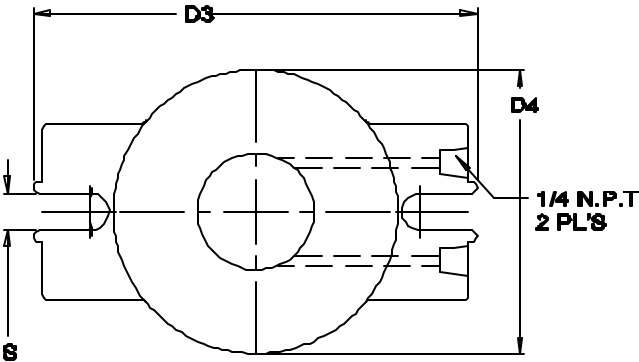

Direction of view is from the driver end of pump.

Suggested Environmental Controls

Piping Details



DOUBLE CARTRIDGE SEAL MODELS

It is recommended that the seal cavity be vented through the pump's lantern ring connection located at top dead center available on some pump models. It is recommended that a flush injection be utilized into the stuffing box in addition to the piping listed below.

NOTE: All rotations as viewed from driver end of pump.

FORCED CIRCULATION (API PLAN 54)

NOTE: It is also recommended that an API Plan 97 or 98 piped to the stuffing box connection be utilized.

WHEN TWO PORTS ARE POSITIONED SIDE BY SIDE ON ONE SURFACE:

PORTS POSITIONED AT 12:00 O'CLOCK:

- **Clockwise shaft rotation:** The cool fluid enters through the right port and the hot fluid exits through the left port.
- **Counter clockwise shaft rotation:** The cool fluid enters through the left port and the hot fluid exits through the right port.

PORTS POSITIONED ON RIGHT SIDE 3:00 O' CLOCK:

- **Clockwise shaft rotation:** The fluid enters through the lower port and exits through the upper port.
- **Counter clockwise rotation:** The fluid enters through the upper port and exits through the lower port.

PORTS POSITIONED ON LEFT SIDE 9:00 O' CLOCK:

- **Clockwise shaft rotation:** The fluid enters through the upper port and exits through the lower port.
- **Counter clockwise shaft rotation:** The fluid enters through the lower port and exits through the upper port.

WHEN TWO PORTS ARE POSITIONED ON TWO SURFACES 180 DEGREES APART:

-- **Clockwise or counter clockwise shaft rotation:** The fluid enters through the lower port (port position recommended at 6:00 o'clock) and exits through the upper port (port position recommended at 12:00 o'clock).

exits

WARNING: Take all necessary precautions and follow safety procedures before starting the equipment.

CONVECTION TANK SYSTEMS (API PLAN 52 AND 53, ETC.) PUMPING RING MODELS ARE RECOMMENDED

NOTE: It is also recommended that an API Plan 11 or 13 piped to the stuffing connection be utilized.

WHEN TWO PORTS ARE POSITIONED SIDE BY SIDE ON ONE SURFACE:

PORTS POSITIONED AT 12:00 O' CLOCK (PREFERRED POSITION):

- **Clockwise shaft rotation:** The cool fluid, from the bottom of the convection tank, enters through the right port and the hot fluid exits the seal through the left port and goes to the top of the convection tank.
- **Counter-clockwise shaft rotation:** The cool fluid, from the bottom of the convection tank, enters through the left port and the hot fluid exits the seal through the right port and goes to the top of the convection tank.

PORTS POSITIONED ON RIGHT SIDE AT 3:00 O' CLOCK:

- **Clockwise shaft rotation:** The cool fluid from, the bottom of the convection tank, enters through the lower port and the hot fluid exits the seal through the upper port and goes to the top of the convection tank.

NOTE: We do not recommend ports be positioned at 3:00 o'clock for **counter-clockwise** shaft rotation.

PORTS POSITIONED ON LEFT SIDE AT 9:00:

- **Counter-clockwise shaft rotation:** The cool fluid from the bottom of the convection tank enters through the upper port and the hot fluid exits the seal through the lower port and goes to the top of the convection tank.

NOTE: We do not recommend ports be positioned at 9:00 for **clockwise** shaft rotation.

WHEN TWO PORTS ARE POSITIONED ON TWO SURFACES 180 DEGREES APART:

- **Clockwise or counter-clockwise shaft rotation:** The cool fluid, from the bottom of the convection tank, enters through the lower port (port position recommended at 6:00 o'clock) and the hot fluid exits through the upper port (port position recommended at 12:00 o'clock) and goes to the top of the convection tank.

WARNING: Take all necessary precautions and follow safety procedures before starting the equipment.

SUPPLY TANK ASSEMBLIES are used as reservoirs with piping systems for double cartridge seals. These sealing systems are defined as either a thermal convection system or an induced flow circulation system using a pumping device (most commonly a pumping ring) to assure positive flow in the system.

SUPPLY TANK SEALING SYSTEMS OFFER THE FOLLOWING ADVANTAGES:

- Lower initial costs over other environmental control systems.
- The elimination of plant cooling water and drain line piping.
- No auxiliary power is required to operate system.
- The supply tank system provides a comparatively small volume of barrier fluid to minimize dilution of the process fluid.
- The supply tank may use auxiliary devices to monitor liquid level and pressure to obtain maximum seal life.

IMPORTANT: Delta recommends pumping ring design seals be used with convection tanks on all applications.

TWO MODES OF PRESSURIZATION ARE COMMONLY USED:

1. **API PLAN 52 - TANDEM SEAL SYSTEM:** The inboard seal faces are lubricated by the pumped liquid whose pressure is greater than the barrier fluid pressure. The outboard seal faces operate using the buffer fluid that is maintained at a pressure less than stuffing box pressure, normally a non-pressurized supply tank with pressure sensor, to detect process fluid leakage into the seal from the stuffing box. The process fluid will leak into the barrier fluid when failure occurs.
2. **API PLAN 53 - DOUBLE SEAL SYSTEMS:** In this system, both inboard and outboard seal faces are lubricated in the barrier fluid, which is maintained at a pressure greater than the stuffing box pressure. The barrier fluid will leak into the process fluid due to the higher barrier fluid pressure when failure occurs. The barrier fluid should be maintained 15 - 25 PSIG above box pressure.

COOLING FOR DUAL SEAL ARRANGEMENTS:

1. **THERMAL CONVECTION CIRCULATION** relies only upon the barrier fluid heated above the process fluid during operation. The cooler, heavier buffer fluid in the supply tank flows down to displace the lighter, hotter fluid in the seal cavity which creates a thermal syphon effect.
2. **INDUCED FLOW CIRCULATION:** a pumping device (pumping ring) provides a positive flow rather than rely on thermal convection only. This highly efficient system will dissipate combined system heat loads more effectively with supply tanks.

IMPORTANT: Delta recommends pumping ring design seals be used with convection tanks on all applications.

TYPICAL PIPING SCHEMATIC

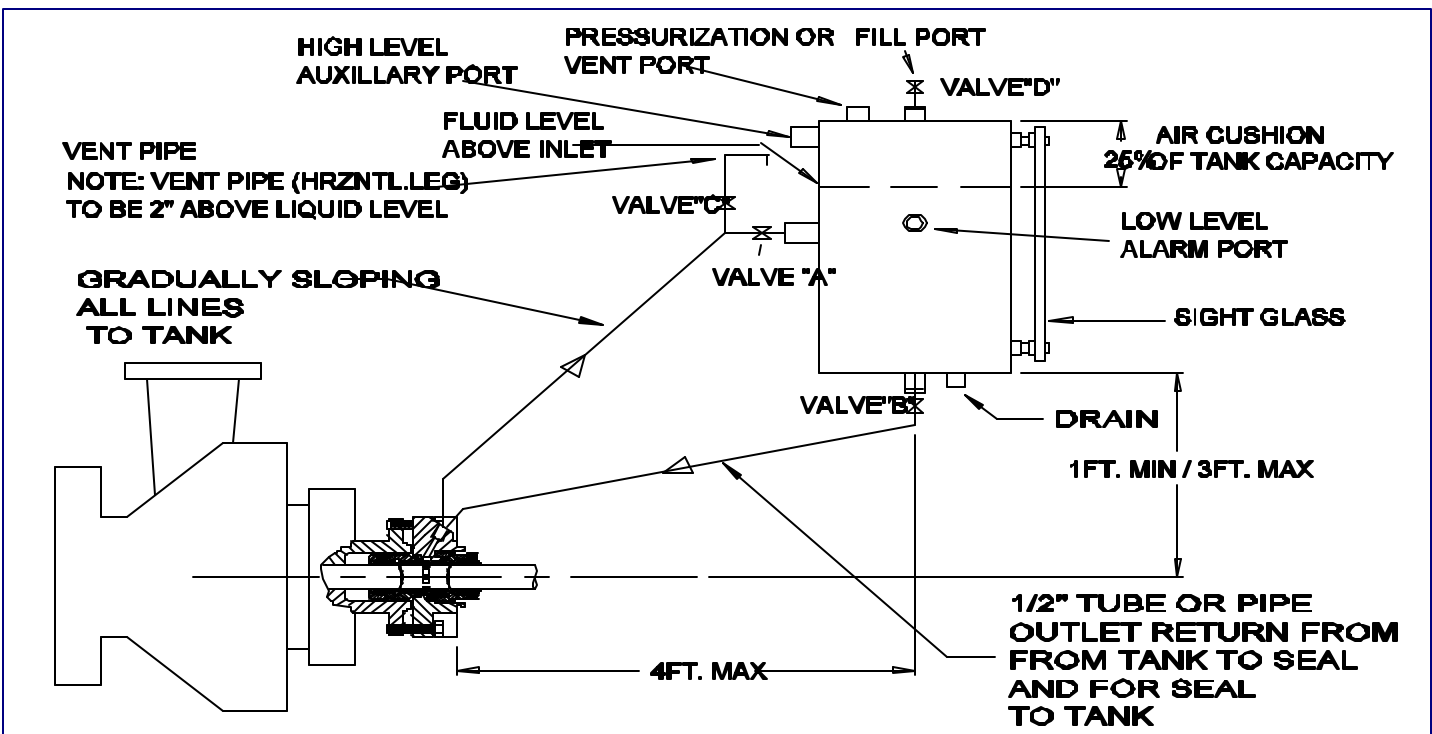

PIPING AND FITTINGS MATERIAL LIST:

1. 1/2" Valves
2. 1/2" I.D. Tubing or Flexible Hosing
3. Nipples with .300" I.D. Minimum
There should be no orifices in the piping system smaller than .300".



INSTALLATION AND STARTUP:

1. Locate the supply tank a minimum of one foot vertically above the sealing cavity and within four feet of the sealing cavity.
Reason: The supply tank must be a point higher than the sealing cavity in order to bleed air from the seal. Natural convection is not going to occur if the cooler, more dense fluid is already at the lowest point in the system.
2. All lines running from the sealing cavity to the supply tank must slope vertically upward.
Reason: Air will be trapped in the lines causing stoppage of liquid flow.
3. Use a minimum of 1/2" diameter tubing and 1/2" diameter valves for piping the system.
Reason: Small orifices, 1/8" diameter tubing, etc., will restrict flow and are easily blocked by dirt or debris which may be in the system.
4. Before starting the system, bleed all air from the highest point in the system (Vent pipe).
Reason: An air pocket at any point in the system will stop flow and centrifugal force can cause air to collect in the seal, resulting in a dry running condition.
5. Maintain a liquid level in the supply tank a minimum of one or more inches above the return line connection to the tank.
Reason: Flow will be stopped if the liquid level falls below the return line elevation.
6. Provide an air cushion at the top of the supply tank equivalent to approximately 25% the volume of the tank.
Reason: An air cushion is required to prevent over pressurizing the seal when increasing temperature and resulting volume increases occur.
7. Proper sealing fluid pressure on your system should be maintained at all times. This will vary with the application and depends upon the type of sealing system used.
Double Seals - Maintain a minimum of 15 - 25 PSIG above the expected box pressure on the seals at all times.
Tandem Seals - Normally operate at atmospheric pressure. Do not fluctuate the pressure in the reservoir frequently while the seals are running as this may cause foaming of the barrier fluid, resulting in stoppage of flow and excessive heat buildup in the seal.

SYSTEM VENTING PROCEDURE:

1. **Close** valves A and B.
2. **Fill tank** level at least 1" above tank connection for return line from seal. (Provide 25% of tank volume for air pocket above liquid level to prevent foaming due to excessive temperature build up.)
3. **Open** lower line valve B.
4. **Open vent pipe** valve C and bleed the air out of the system. (The horizontal leg of the vent piping should be 1 to 2 inches above the liquid level in tank.)
5. **Open valve A.**
6. **Close vent pipe** valve C.
7. **Close valve "D"** and plug all ports on the tank.
8. **Follow plant startup** procedures and all procedures found in the installation instructions.

STARTUP:

When pump or equipment is started, check the temperature of the tubing at the seal. Within 60 seconds, a temperature difference between the inlet and outlet line should be detectable. Within two to three minutes, the outlet line from the seal should be warm along its entire length and the inlet line should remain cool. If both lines become hot at the seal gland then the system is not fully primed. Repeat the venting procedures to evacuate all air from the system.

WARNING: **Make sure there is no pressure on the tank.**

NOTE: Some systems may have reverse flow of the barrier fluid. Refer to the installation instructions for proper re-centering/setting of the seal as minor radial misalignment may effect flow. Make sure washers are used on gland bolts, as this condition commonly causes the gland to be off centered to the seal sleeve.

Check that the fluid level remains stable with no evidence of leakage. As the system temperatures stabilize over the first few hours, check that the seal inlet/outlet difference does not exceed 25 degrees C (45 degrees F) and that the outlet temperature does not exceed 70 degrees C (160 degrees F).

WARNING: **Take all necessary precautions and follow all safety procedures before starting the equipment.**

FORCED CIRCULATION SYSTEM INFORMATION API PLAN 54 (Using a standard single flow meter)

Forced circulation system API Plan 54 depicted is a piping schematic which uses a barrier fluid system such as a plant service water line. Both inboard and outboard seals operate in the barrier fluid environment. Leakage will be into process fluid if the barrier fluid pressure is higher. The forced circulation system pressure may also be regulated lower than stuffing box pressure there by preventing barrier fluid from entering the process stream. In this scenario process fluid will enter the barrier fluid system when the inboard seal fails.

PIPING DETAIL FORCED CIRCULATION API PLAN 54 (Using a standard single flow meter)

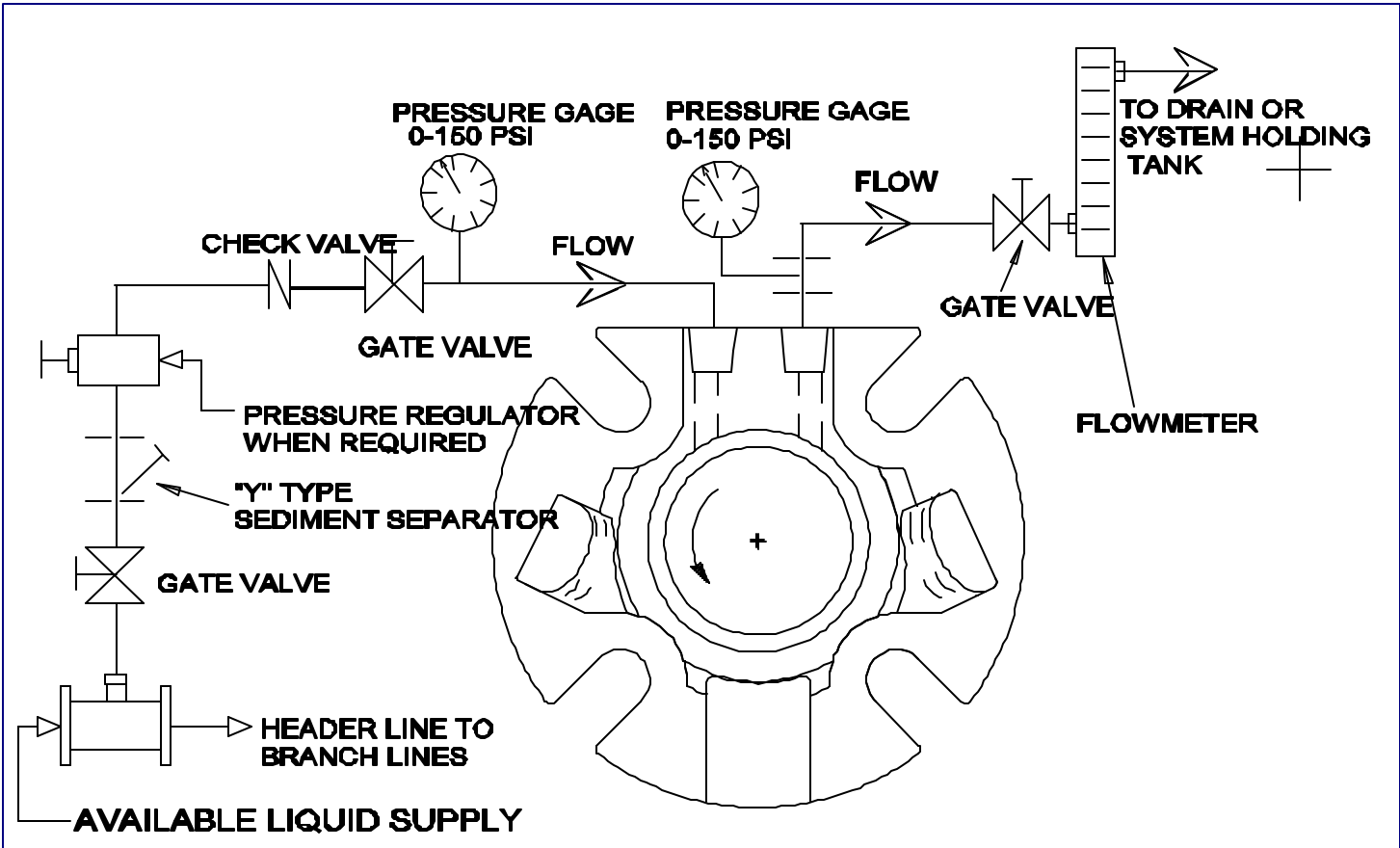

START UP:

1. Prior to start up of equipment, open all valves on barrier fluid system and adjust flow to a steady stream.
2. Follow plant start up procedures and all procedures found in the installation instructions.
3. Adjust the amount of flow for adequate cooling of the mechanical seal. Outlet line should be warm to touch at outlet of seal.

WARNING: Take all necessary precautions and follow safety procedures before starting the equipment!