

# DELTA O-RING CARTRIDGE SEAL ASSEMBLY AND INSTALLATION INSTRUCTIONS



## INTRODUCTION:

These instructions are provided to familiarize the user with the seal and its use. The instructions must be read carefully and applied whenever work is done on the seal. Please keep available for future reference.

**IMPORTANT:** **These instructions are for the installation and operation of a seal as used in rotating equipment and will help to avoid danger and improve reliability. The information required may change with other types of equipment or installations. These instructions must be read in conjunction with the instruction manuals for both the pump and any auxiliary equipment.**

If the seal is to be used for an application other than that originally intended or outside the recommended performance limits, Delta must be contacted before its installation and use.

Any warranty may be affected by improper handling, installation, or use of this seal. Contact the company for information as to product warranty and limitations of liability.

If questions or problems arise, contact your local Delta Sales/Service Engineer or the original equipment manufacturer, as needed.

**IMPORTANT:** **Delta Mechanical Seals are precision products and must be handled appropriately. Take particular care to avoid damage to lapped sealing faces.**

## SAFETY NOTES:

1. The following designations are used in the installation instructions to highlight areas of particular importance:

**NOTE:** Refers to special information on how to install or operate the seal.

**IMPORTANT:** **Refers to special information towards the prevention of damage to the seal or its surroundings.**

**WARNING:** **Refers to mandatory instructions designed to prevent personal injury or extensive damage.**

2. Installation, removal and maintenance of the seal must be carried out only by qualified personnel who have read and understood all instructions.
3. The seal is designated exclusively for sealing rotating equipment; manufacturer cannot be held liable for use of the seal for purposes other than noted.
4. The seal must only be used in perfect conditions and must be operated within the recommended performance limits in accordance with its designated use set out in these instructions for installation of Delta Mechanical Seals.
5. If the fluid pumped is hazardous or toxic, special care and appropriate precautions must be taken to ensure that any seal leakage is adequately contained. Further information on sealing hazardous or toxic fluids is available from Delta and should be read carefully prior to seal installation.
6. Fluorocarbon components should never be burned or incinerated as the fumes and residues are toxic. If fluorocarbons are accidentally heated above 700 degrees F they decompose, therefore, protective gloves should be worn as acid may be present.
7. PTFE should never be burned or incinerated as the fumes are toxic and dangerous.

## PRIOR TO STARTING EQUIPMENT:

1. Check the pump at the coupling for proper alignment of the motor.
2. Ensure that the gland nuts/bolts are securely tightened and that all screws are securely fastened.
3. Complete the assembly of the pump and turn the shaft to ensure free rotation prior to startup.
4. Consult all equipment operating instructions to check for proper piping and connections, particularly regarding: seal recirculation/flush, heating or cooling requirements, and external services.

**IMPORTANT:** **This mechanical seal is designed to operate in a liquid so the heat created must be removed. The following check should be carried out after seal installation and after any period of equipment inactivity.**

5. Check that all seal chamber lines are open and free from obstruction and ensure that the seal chamber is properly vented and filled with liquid; refer to "Delta Start-up Procedures" and pump instruction manual.

**IMPORTANT:** **Dry-running, often indicated by a squealing noise from the seal area, causes overheating and damage to the sealing surfaces, resulting in excessive leakage and shortened seal life.**

**WARNING:** **Before start-up, make sure all personnel and tools have been moved to a safe distance so there is no contact with rotating components on the pump, coupling, seal and motor.**

**WARNING:** **Seal installation should be handled only by qualified, trained personnel. If questions arise, contact the local Delta Engineer. Improper use or installation of this product could result in injury and/or harmful emissions to the environment, and may affect any warranty on the product. Please contact Delta for information as to exclusive product warranty and liability limitations.**

## AFTER EQUIPMENT HAS RUN:

1. Make sure that the pump is electrically isolated.

**WARNING:** **If the seal has been used on toxic or hazardous fluids, ensure that the seal is correctly decontaminated and safe prior to commencing work.**

**NOTE:** Fluid is often trapped during draining and may exist outside the seal. The pump instruction manual should be consulted for any special precautions.

2. Ensure that the pump is isolated by the appropriate valves. Check that the fluid is drained and pressure is fully released.
3. Make sure work area is safe, secure, and well ventilated.

## SEAL MAINTENANCE:

No maintenance of a seal is possible while installed; therefore, it is recommended that a spare seal (to prevent unnecessary downtime) be held in stock to allow immediate replacement of a removed seal.

**WARNING:** **It is the responsibility of the user to ensure that any parts being sent to a third party have appropriate, safe-handling instructions externally attached to the mechanical seal packaging.**

## DELTA QUALITY ASSURANCE:

This seal has been assembled in accordance with Delta Quality Assurance Standards. With proper maintenance and use, it will give safe and reliable operation to the maximum recommended performance as shown in Delta publications.

**INSTALLATION INSTRUCTION FOR DELTA 4200**



1. Stationary faces utilize .062 gaskets on appropriate sealing surfaces.
2. If stationary design utilizes an o-ring, check o-ring and face material compatibility with the process fluid.
3. Determine the correct installation length (operating length) using the installation instructions for the rotary unit used.
4. Stationary Centering: The stationary should be centered to clear the shaft using either:
  - (A) enclosed plastic gauges (if supplied)
  - (B) by use of feeler gauges
  - (C) If stationary is piloted into equipment counter bore with close fitting tolerances, the use of gauges is not required.

**IMPORTANT:** It is important that the stationary ID be centered around the shaft sleeve OD. Prior to starting the equipment, rotate the equipment by hand. If any binding or rubbing occurs, loosen gland bolting and recenter the stationary.

# DIMENSIONAL DATA FOR DELTA SEAL STYLE

# 4200



Front View

Side View

Optional Gland Feature

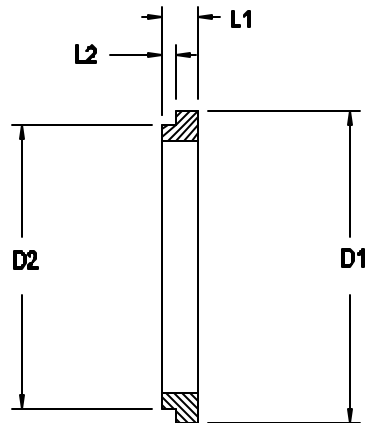

DS Seal Size	D1 Major OD	D2	A Min. Bolt Circle by Stud Size				L1 Overall Length	L2	L3	Pos. 1 Oring	Pos. 2 Oring	Pos. 3 Oring	Pos. 4 Oring	Pos. 5 Oring	Pos. 6 Oring
			3/8"	1/2"	5/8"	3/4"									
			0.625	1.630											
0.750	1.750					0.500									
0.875	1.880					0.500									
0.937	1.940	1.557				0.625	0.250								
1.000	2.090	1.620				0.625	0.250								
1.125	2.220	1.745				0.625	0.250								
1.1875	2.440	1.807				0.625	0.250								
1.250	2.340	1.870				0.625	0.250								
1.375	2.410	1.995				0.625	0.250								
1.437	2.560	2.166				0.625	0.250								
1.500	2.720	2.245				0.625	0.250								
1.625	2.840	2.370				0.625	0.250								
1.6875	3.090	2.495				0.625	0.250								
1.750	3.090	2.495				0.625	0.250								
1.875	3.220	2.620				0.625	0.250								
2.000	3.470	2.745				0.625	0.250								
2.125	3.720	2.870				0.625	0.250								
2.250	3.840	2.995				0.625	0.250								
2.375	3.880	3.057				0.625	0.250								
2.500	4.090	3.245				0.625	0.250								
2.625	4.220	3.370				0.625	0.250								
2.750	4.380	3.615				1.000	0.250								
2.875	4.500	3.740				1.000	0.250								
3.000	4.560	3.865				1.000	0.250								
3.125	4.690	3.990				1.000	0.250								
3.250	4.880	4.115				1.000	0.250								
3.375	5.000	4.240				1.000	0.250								
3.500	5.1300	4.365				1.000	0.250								

**Distributor**

(Phone)  
(Fax)



**Manufacturer**

Delta  
44 Propper Lane  
Fall River, MA 02720  
508-324-4032 (Phone)  
508-324-4339 (Fax)