

DELTA STYLE 9500 CARTRIDGE SPLIT SEAL INSTALLATION INSTRUCTIONS



INTRODUCTION:

The Type 9500 Cartridge Split Seal sets the standard in the evolution of split seal designs. It is well suited for the widest variety of applications, such as: condensate, paper stock, sludge, and river water. It can be installed on both horizontal and vertical equipment, including pumps, mixers, and agitators, where reliability and minimal downtime are essential.

These instructions are provided to familiarize the user with the seal and its use. The instructions must be read carefully and applied whenever work is done on the seal. Please keep these instructions available for future reference.

IMPORTANT: **These instructions are for the installation and operation of a seal as used in rotating equipment and will help to avoid danger and improve reliability. The information required may change with other types of equipment or installations. These instructions must be read in conjunction with the instruction manuals for both the pump and any auxiliary equipment.**

If the seal is to be used for an application other than that originally intended or outside the recommended performance limits, Delta must be contacted before its installation and use.

Any warranty may be affected by improper handling, installation, or use of this seal. Contact the company for information as to product warranty and limitations of liability.

If questions or problems arise, contact your local Delta Sales/Service Engineer or the original equipment manufacturer, as needed.

IMPORTANT: Delta Mechanical Seals are precision products and must be handled appropriately. Take particular care to avoid damage to lapped sealing faces.

SAFETY NOTES:

1. The following designations are used in the installation instructions to highlight areas of particular importance:

NOTE: Refers to special information on how to install or operate the seal.

IMPORTANT: Refers to special information towards the prevention of damage to the seal or its surroundings.

WARNING: Refers to mandatory instructions designed to prevent personal injury or extensive damage.

2. Installation, removal and maintenance of the seal must be carried out only by qualified personnel who have read and understood all instructions.
3. The seal is designated exclusively for sealing rotating equipment; manufacturer cannot be held liable for use of the seal for purposes other than noted.
4. The seal must only be used in perfect conditions and must be operated within the recommended performance limits in accordance with its designated use set out in these instructions for installation of Delta Mechanical Seals.
5. If the fluid pumped is hazardous or toxic, special care and appropriate precautions must be taken to ensure that any seal leakage is adequately contained. Further information on sealing hazardous or toxic fluids is available from Delta and should be read carefully prior to seal installation.
6. Fluorocarbon components should never be burned or incinerated as the fumes and residues are toxic. If fluorocarbons are accidentally heated above 700 degrees F they decompose, therefore, protective gloves should be worn as acid may be present.

PRIOR TO STARTING EQUIPMENT:

1. Check the pump at the coupling for proper alignment of the motor.
2. Ensure that the gland nuts/bolts are securely tightened and that all screws are securely fastened.
3. Complete the assembly of the pump and turn the shaft to ensure free rotation prior to startup.
4. Consult all equipment operating instructions to check for proper piping and connections, particularly regarding: seal recirculation/flush, heating or cooling requirements, and external services.

IMPORTANT: **This mechanical seal is designed to operate in a liquid so the heat created must be removed. The following check should be carried out after seal installation and after any period of equipment inactivity.**

5. Check that all seal chamber lines are open and free from obstruction and ensure that the seal chamber is properly vented and filled with liquid; refer to "Delta Start-up Procedures" and pump instruction manual.

IMPORTANT: **Dry-running, often indicated by a squealing noise from the seal area, causes overheating and damage to the sealing surfaces, resulting in excessive leakage and shortened seal life.**

WARNING: **Before start-up, make sure all personnel and tools have been moved to a safe distance so there is no contact with rotating components on the pump, coupling, seal and motor.**

WARNING: **Seal installation should be handled only by qualified, trained personnel. If questions arise, contact the local Delta Engineer. Improper use or installation of this product could result in injury and/or harmful emissions to the environment, and may affect any warranty on the product. Please contact Delta for information as to exclusive product warranty and liability limitations.**

AFTER EQUIPMENT HAS RUN:

1. Make sure that the pump is electrically isolated.

WARNING: **If the seal has been used on toxic or hazardous fluids, ensure that the seal is correctly decontaminated and safe prior to commencing work.**

WARNING: **Split seals are not recommended for hazardous or toxic fluids. Please contact Delta for information regarding the use of split seals on specific fluids.**

NOTE: **Fluid is often trapped during draining and may exist outside the seal. The pump instruction manual should be consulted for any special precautions.**

2. Ensure that the pump is isolated by the appropriate valves. Check that the fluid is drained and pressure is fully released.
3. Make sure work area is safe, secure, and well ventilated.

SEAL MAINTENANCE:

No maintenance of a seal is possible while installed; therefore, it is recommended that a spare seal (to prevent unnecessary downtime) be held in stock to allow immediate replacement of a removed seal.

WARNING: **It is the responsibility of the user to ensure that any parts being sent to a third party have appropriate, safe-handling instructions externally attached to the mechanical seal packaging.**

DELTA QUALITY ASSURANCE:

This seal has been assembled in accordance with Delta Quality Assurance Standards. With proper maintenance and use, it will give safe and reliable operation to the maximum recommended performance as shown in Delta publications.

All Delta Mechanical Seals products must be installed in accordance with Delta's installation instructions. Failing to do so or attempting to change or modify Delta's products will void Delta's limited warranty. Delta's limited warranty is described fully in Delta's Standard Terms and Conditions of Sale. Delta makes no warranty of merchantability or fitness for a particular purpose and in no event shall Delta be liable for consequential or incidental damages.

EQUIPMENT PREPARATION



PREPARING EQUIPMENT:

1. Remove the packing follower or existing seal. If the follower is not split, it must be cut in half to be removed without further disassembly of the pump.
2. Remove the pump studs.

SHAFT / SLEEVE EXAMINATION:

1. The shaft finish should be 30 micro inches RMS and feel smooth if you run your fingernail down it axially
2. Make sure the shaft or sleeve diameter is within + .000"/- .002" of nominal.
3. Use a dial indicator to measure the shaft runout in the area where the seal will be installed. (Readings should not exceed .002" TIR per inch of shaft diameter on typical centrifugal pumps).
4. Place the dial indicator on the end of the shaft and alternately push and pull the shaft axially to measure end play. (End play should not exceed .005" TIR on typical centrifugal pumps).

IMPORTANT: On low speed equipment, typically mixers and agitators, seal design will accommodate shaft runout of .062 on seal sizes up to 2.625 and .100 on sizes 2.750 - 5.250. Axial shaft movement (end play) up to .015.

5. A static o-ring (position 1) must seal to the shaft at the location shown in seal cutaway drawing on page 8. Be sure the shaft is clean and free from scratches or any type of deposits within the o-ring area.
6. Remove all burrs and sharp corners, especially in areas where the position 1 o-ring has to slide and is set after installation (approx. .875 from face of box).

STUFFING BOX/SEAL CHAMBER EXAMINATION:

7. Clean out the seal chamber. Remove all the old packing rings and any lantern rings.
8. Clean the seal chamber face area, scraping off any loose rust or paint chips. The seal chamber face should be flat and clean to provide a suitable sealing surface for the gland o-ring.
9. Check that the stuffing box/seal chamber is clean with no obstructions.
10. The stuffing box face should be a maximum of 125 micro inches RMS for proper gasket sealing.
11. Attach the dial indicator base to the shaft and rotate both the indicator and shaft while reading the runout of the stuffing box face. Misalignment of the stuffing box face relative to the shaft should not exceed .003" TIR per inch of shaft diameter.
12. Some split case pumps will have a misalignment between halves on the stuffing box face. This surface must be machined flat. Also, make sure there is sufficient casing gasket extending between the casing halves of the pump to seal against the gland gasket.

PUMP/DRIVER ALIGNMENT:

13. Check the driver shaft (motor) to equipment shaft (pump) alignment using a dial indicator or precision alignment procedure.

NOTE: If any values in the above steps are found to be out of tolerance, corrective actions must be taken to ensure extended seal life.

INSTALLING THE SEAL:

NOTE: Seal mounting bolts are not included with this seal. Prior to beginning seal installation, obtain seal mounting bolts to replace studs in equipment housing. Hex head bolts with washers are recommended. When sizing bolts, reference seal cutaway drawing (page 8) for gland thickness, and be sure to allow for proper thread engagement into the equipment housing.

1. Before starting the installation, read the following instructions carefully.
2. Remove the seal from its packaging, inspect for any damage, and wipe clean.

IMPORTANT: Do not fit the rotary and stationary faces together before actual installation. Both seal faces are machined as rings, and then split into two halves. Peaks and valleys on one half will mate exactly with the other half, providing accurate alignment. However, when the halves are repeatedly engaged and separated, small pieces may break loose, resulting in an imperfect fit between the parts. This may result in excess leakage. Since a split seal is installed with the pump in place, special attention must be paid to keeping the seal area as clean as possible.

3. Verify that the metallurgy, faces, and o-rings are compatible with the fluid to be sealed.
4. The equipment should be cleaned and comply with the "Equipment Preparation" procedures.
5. Fasteners included for installation. (Fig: 1A)

FIG: 1A

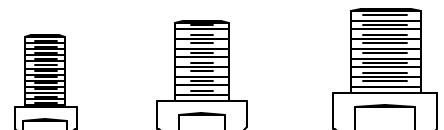

Band clamping screw
2 Each

Shaft Clamping
screw 2 Each

Gland half screws
4 Each

Seal Sizes	Fastener Size
1-437 - 2.625	6-32 10-24
2.750 - 5.250	8-32 1/4-20
	1/4-20 3/8-16

STEP 1 INSTALLING THE ROTARY ASSEMBLY TO EQUIPMENT SHAFT/SLEEVE:



1. Remove the rotary assembly halves from their packaging.
2. Lay rotary holder, with faces up, flat on a clean, flat surface, remove shaft clamping screws and band clamping screws and separate holder halves.

IMPORTANT: Do not fit the seal faces together again before actual installation.

3. Take rotary half that has o-ring affixed to the face and lubricate the O. D. and I. D. of the entire o-ring liberally with the o-ring lubricant provided.

IMPORTANT: Lift the long portion of the o-ring out of the channel and liberally lubricate the entire o-ring surface (I.D. and O.D. of o-ring) up to the point it is glued to the rotary face then return the long portion of the o-ring back to the o-ring channel. Gently pull back short end and lubricate entire o-ring surface up to the adhesive point. Be careful not to tear o-ring from the point it is glued to the rotary face.

STOP: It is very important the entire o-ring is liberally lubricated as described above, if not the face halves will not align properly at the face joints.

IMPORTANT: Take care to prevent any deposits, foreign material, and grease from getting on the joint surfaces of the seal faces.

- 5.A) Place rotary half, with o-ring, on the underside of the shaft/sleeve with rotary seal face away from stuffing box and the back of the rotary holder flush with the stuffing box face.

IMPORTANT: B) Place a liberal amount of lubricant on the shaft under the o-ring as shown between arrows in Fig: 1 and on the two ends of the o-ring where they meet. This will help to hold the o-ring in place and keep the ends touching when assembling the second half of the rotary holder

- C) Bring the long end of the o-ring over the top of the shaft/sleeve and match to the other butt-joint end of the o-ring.

IMPORTANT: The ends of the o-ring must be touching before installing the second half of the rotary holder. This assures a leak-free joint when assembled.

- 6.A) Position second half of rotary holder assembly over the top of shaft/sleeve, aligning the o-ring groove in the rotary holder half with the o-ring on the shaft
- B) Lower the holder assembly evenly.
- C) Match up the alignment pins, and start the medium size shaft clamping screws (closest to stuffing box face) on each side of the rotary holder.

IMPORTANT: Do not tighten the small band clamping screws until step 13 (after shaft clamping screws are tight.)

- D) Bring screws down evenly on each side. Screw should be finger tight and the gap between the rotary holder halves should be equal.

- E) The rotary holder assembly should be loose enough to slide along the shaft.

FIG: 1

- 5B) Lubricate ends of o-ring and make sure they are touching before installed 2nd half of rotary holder in step 6.
- 5C) Bring long end of the o-ring over top of the shaft and meet up with the short end of the o-ring

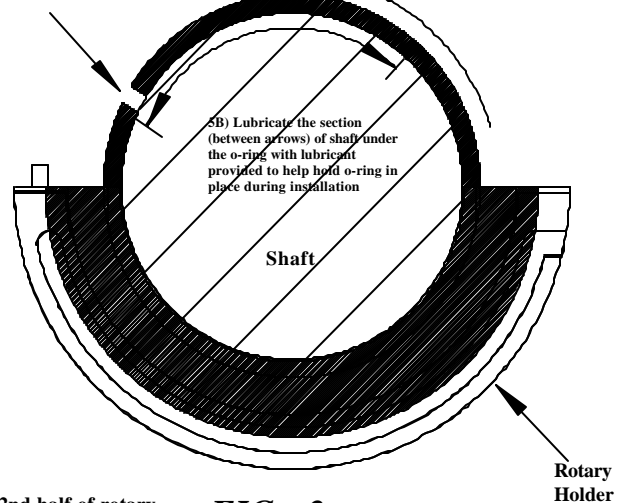

- 6B) Bring 2nd half of rotary holder down over shaft

FIG: 2

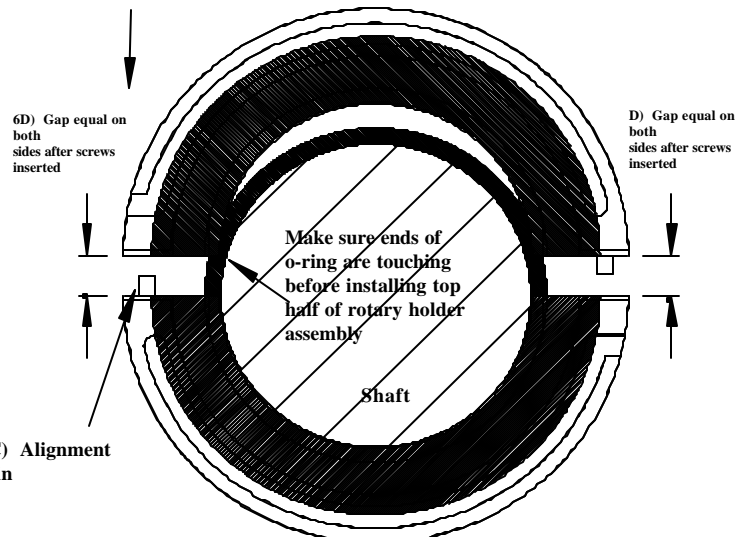

- Place a pocket scale (provided) on back ridge of rotary holder assembly and slide the assembly back against the stuffing box face (as shown in Fig: 3). This provides the correct operating length (spring load) when the gland is installed.

IMPORTANT: In the event that the stuffing box I.D. is small enough that there is contact between the stuffing box face and the rotary holder, move the rotary holder away from the stuffing box .010 and proceed to the next step

- Evenly tighten the larger screws in the rotary holder halves to secure the assembly to the shaft/sleeve. (Visually check to make sure the gap between the rotary holder halves are equal on each side.) Tighten screws alternately 1/4-1/2 turn at a time until both screws are tight.
- Remove pocket scale used in setting rotary holder assembly to seal chamber face. If possible, perform a visual inspection making sure the back of the rotary holder is flush with the stuffing box face.

IMPORTANT: Maintaining an even gap on each side of the rotary holder ensures perpendicularity of holder to the shaft.

- Insert the band clamping screws into each rotary holder half and start the screws into the threaded holes but do not tighten.

IMPORTANT: Make sure the face has not rotated in the holder. The joint halves of the face must line up with the joint halves of the rotary holder.

NOTE: Visually check behind the O.D. of the rotary face to see if there are face aligning springs behind the face. If there are, you can skip step 12A and 12B and continue with step 13A.

- Insert pocket scale (provided) between the front edge of the rotary holder half and backside of the face at 90 degrees from the split half (part line) of the holder.
 - Gently pull each face half forward to align faces with pocket scale until it stops.

IMPORTANT: Repeat steps 12A & 12B a second time before tightening the band screws. This ensures faces are perpendicular to the equipment shaft and prevents misalignment of the seal faces.

IMPORTANT: Before proceeding, make sure hands are clean when feeling/aligning the face halves. Any foreign material between the joint surfaces of the seal faces may prevent their alignment and create a path of leakage. Seal faces are flat to within .000035". As with any other seal, assuring the seal face halves are aligned is extremely important to assure a leak free seal.

- Tighten the small size band clamping screws evenly until the faces lightly contact each other.
 - Check the split joint for any mismatching between the seal face halves, by rubbing your finger over the face joint on the lapped surface to feel for any high spots (See Fig: 4)

NOTE: If holder is equipped with face aligning springs, step 13B may not be necessary as the face joints may align automatically as the two band screws are evenly tightened and brought to the full torque value. A final "touch" of the faces is done in step 15.

NOTE: Adjustment steps C and D are typically not required as face aligns automatically using face aligning springs or in steps 12A to 12B. If the holder does not have springs.

- If required, correct by loosening band screws and gently adjusting the faces until they are perfectly aligned and flush. Push down with finger on the half that is high or repeat step 12A if needed.

- Check that the split joints are flush on the O.D. surface of the face and gently adjust if required. (See FIG: 4A)

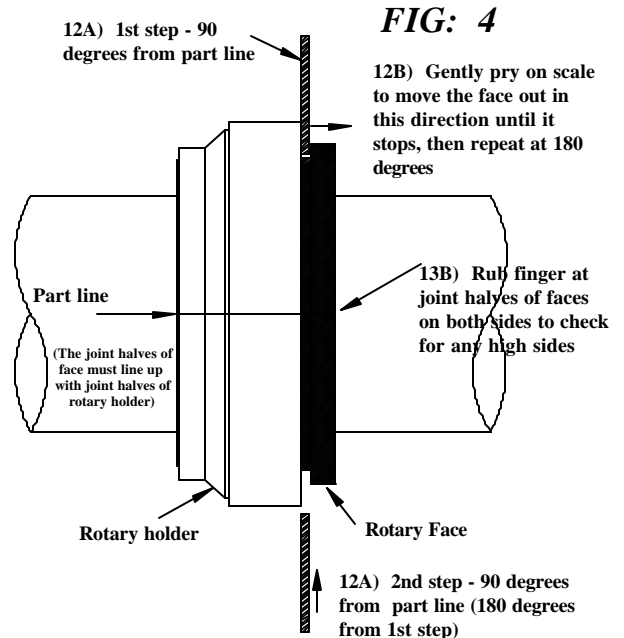
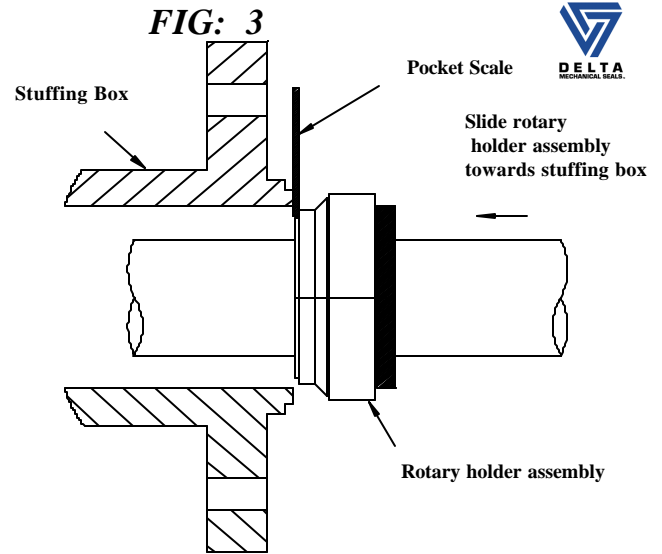

13D) O.D. of rotary face halves should be flush (No Steps)

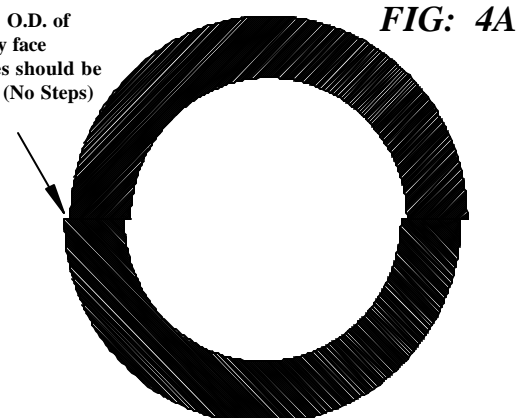

14. Tighten the band clamping screws equally continually checking to make sure the faces are aligned.
15. Before final tightening of band screws, perform a final check of the seal face joint. Use a finger to feel across the face and on the O.D. surface where both halves meet. There should not be a detectable ridge. If there is, loosen the band clamping screws and repeat steps 12-15 until the face joints are aligned to the touch of a finger.

IMPORTANT: Only torque screws to final recommended specification after joint alignment of the face is achieved, as you can damage the face if it is not aligned when fully tightened.

Band Clamp Screw Seal Size	Torque Specifications Torque spec.
1.437" to 2.625"	15 in lbs
2.750" to 5.250"	30 in lbs

IMPORTANT: IF FACE HALVES DO NOT ALIGN, STOP:

1. make sure the entire surface of the o-ring (I.D. and O.D.) has been liberally lubricated as described in step 3 above. The o-ring must be properly lubricated in order for the face halves to align properly.
2. If the entire o-ring under the rotary face has been liberally lubricated and faces will not align after several attempts, it is possible that a piece of foreign material was caught between the faces during the assembly. The following steps then must be taken:
 - A.) Remove rotary holder from shaft using page 1 of the 9500 rebuild kit/repair instructions following step 3-6 in the "Removing Seal From Equipment" section.
 - B.) Inspect the joint halves of the faces for any contaminants.
 - C.) Spray joint halves with alcohol or rinse each end in a small cup of alcohol and blow dry with shop air.
 - D.) Repeat step I (4-15) of the installation instructions.
3. If face halves still do not align after taking the above steps, verify shaft is clean and to correct tolerance.

STEP II INSTALLING GLAND HALVES OVER ROTARY HOLDER:

1. The Delta 9500 Split Seal comes with the stationary seal faces and o-rings pre-installed in the gland halves.
2. Remove gland half assemblies from packaging, lay gland on table with gasket surface up and remove the four screws holding halves together, then carefully pull halves apart.

NOTE: New Seals come with o-ring lengths preset from factory. Perform a visual inspection of o-ring lengths listed in step 3, if acceptable, continue with step 4.

FIG: 5

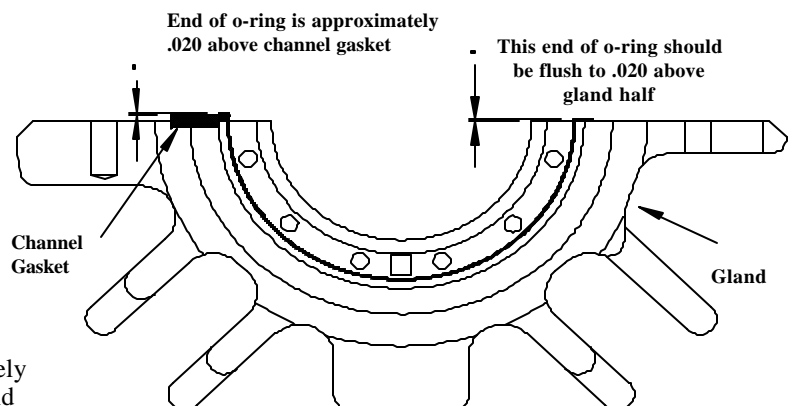

3. Make sure the o-ring sticks out of the gland half approximately .020 above the channel gasket on that side of the gland and flush to .020 above the gland half on the side without the channel gasket.

IMPORTANT: O-ring should be sticking out each side of the gland. It should be sticking .020 above the channel gasket on that side of the gland and flush with the gland half on the side of the gland without the channel gasket.

IMPORTANT: Take care so that the joint surfaces of the stationary face are free from any deposits or foreign material. If there are any visible contaminants, spray with alcohol and blow dry with shop air.

FIG: 6 (Front)

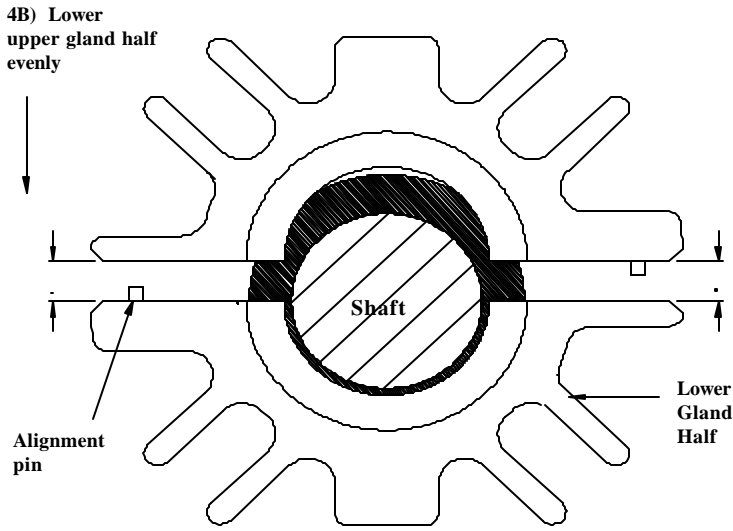
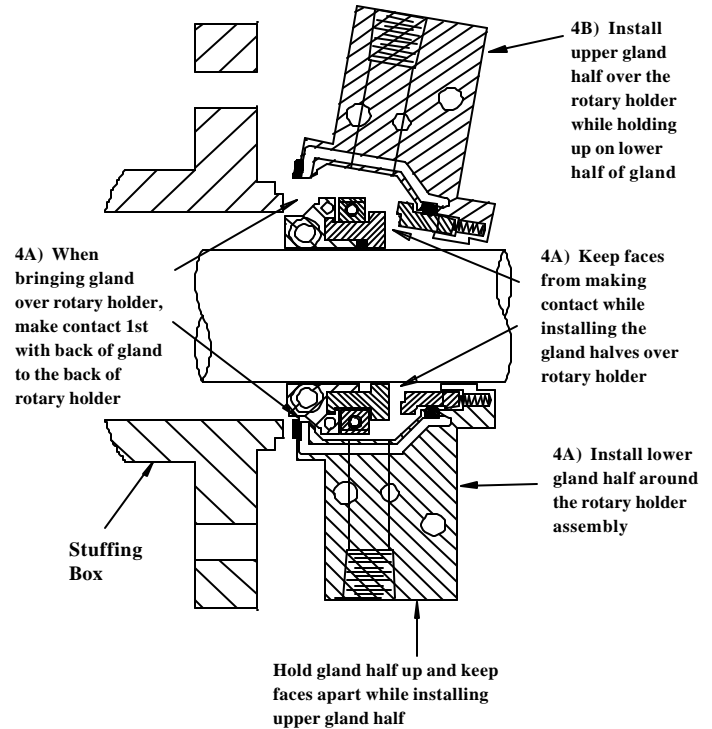

FIG: 6 (Side)



IMPORTANT: During the following step when bringing the gland halves over the rotary holder assembly, the rotary seal face and seal faces in the gland halves must not make contact with each other. (See Fig: 6 side view)

- 4.A) Install the lower half of the gland assembly half around the rotary holder assembly. Take care not to allow the seal faces to make contact with each other.
- B) Bring the remaining gland half down evenly over the rotary holder assembly, matching up the alignment pins while supporting the lower half of gland in position as shown in FIG: 6.
5. Install and finger tighten the gland cap screws. (Gap between gland halves is approximately .020 on each side)

NOTE: When inserting socket head cap screws, make sure the screw is inserted into the hole without threads and screws into the other half, drawing the two halves together when tightened.

IMPORTANT: 6. Slide gland assembly squarely towards the stuffing box and gently push so that the faces compress against each other and then release. The springs should push the gland away from the stuffing box when released. This step ensures that the stationary face halves align properly before the final tightening of the gland halves.

7. While supporting the weight of the gland with your hand and again holding the gland away from the stuffing box face (so that the seal faces are not contacting each other) fully tighten the screws holding the gland halves together.

IMPORTANT: When tightening, hold gland away from the rotary holder assembly to keep the faces apart and prevent them from being damaged.

STEP III TIGHTEN GLAND TO EQUIPMENT:

1. Slide the gland assembly forward to the stuffing box. This will automatically provide the correct spring force on the stationary face assembly when tightened.

NOTE: If the gland came with centering shim material pre-installed, skip step 2 and 3 and proceed to step 4.

2. Install and evenly tighten seal mounting bolts finger tight. The gland should still be able to be moved in order to center it to the shaft/sleeve.

3. Install the centering shim material between the shaft/sleeve O.D. and the machined I. D. in the front of the gland (See Fig: 7).

Start with one end of the centering material and work your way around the shaft until the entire piece is around the shaft/sleeve and between the gland machined I. D. and the shaft/sleeve.

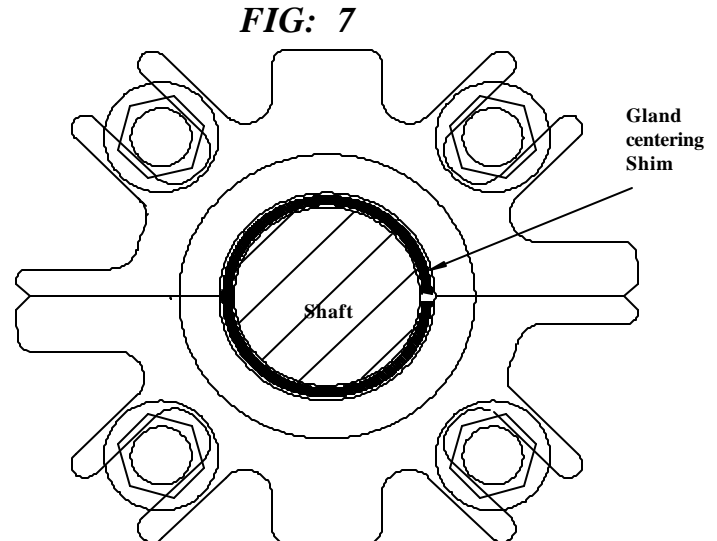

4. Evenly tighten seal mounting bolts in an alternate pattern until secure (1/4 turns 180 degrees apart). Make sure heavy duty flat washers are used, failure to do so may cause the gland to move off center.

IMPORTANT: Do not over-tighten the seal mounting bolts as gland distortion will result in leakage between gland halves.

5. Remove the gland centering shim.

6. Seal assembly should look like Fig: 8 when complete.

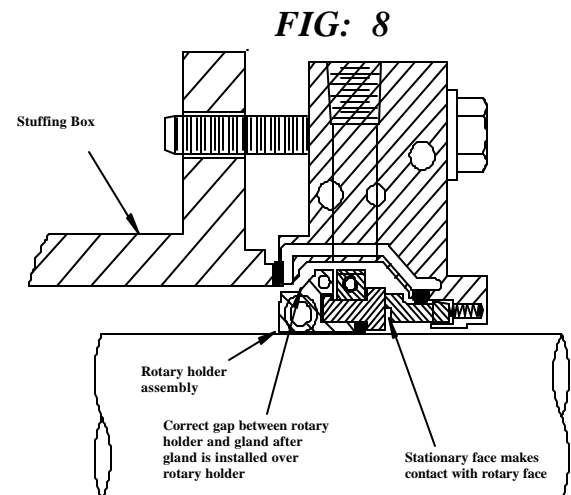

IMPORTANT: Orient the piping connections per the instructions outlined in the "Gland Front View/Piping Arrangement" and "Piping Details" (page 8). Do not connect piping until after gland bolts/nuts have been tightened!

7. It is important to check that the rotary holder is centered in the gland. To accomplish this, turn the shaft by hand to make sure that it turns freely. If you hear metal to metal contact within the seal, the seal must be re-centered. Go back and perform steps 2 - 5.
8. Make appropriate piping connections to the seal assembly and equipment. See "Gland Front View/Piping Arrangements" and "Piping Details", "Environmental Controls" (page 8). Piping connections can only be made after the gland bolts/nuts are securely tightened.

TYPICAL STYLE 95LS SEAL ARRANGEMENT



Seal Cutaway

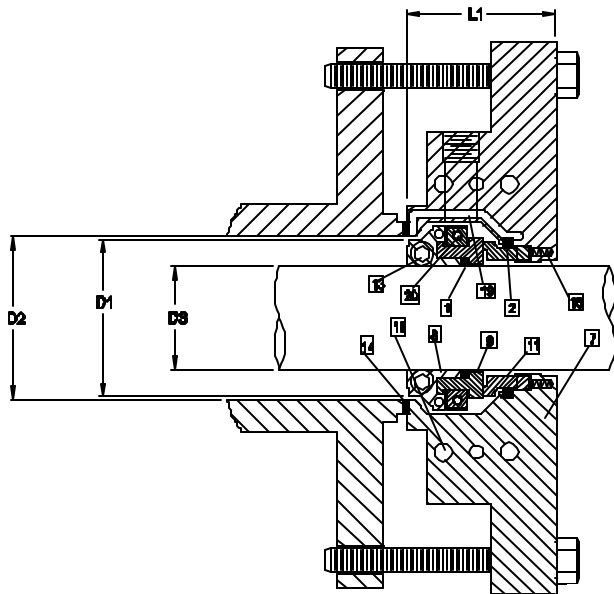

Seal Cutaway/Part Identification Key

Item	Description	Part Number
1	O-ring Pos.1	Standard
2	O-ring Pos.2	Standard
3	O-ring Pos.3	N/A
4	O-ring Pos.4	N/A
5	O-ring Pos.5	N/A
6	O-ring Pos.6	N/A
7	Gland	Standard
8	Rotary Face Holder	Standard
9	Inboard Rotary Face:	Standard
10	Outboard Rotary Face:	N/A
11	Inboard Stationary Face:	Standard
12	Outboard Stationary Face:	N/A
13	Set Screws / Lock Collar	Standard
14	Gasket	Standard
15	Snap Ring	N/A
16	Springs	Standard
17	Centering Device	(Not Shown)
18		
19	Channel Gasket	Standard
20	Band Clamping Screw	Standard

Additional Products

Gland Front View / Piping Arrangement

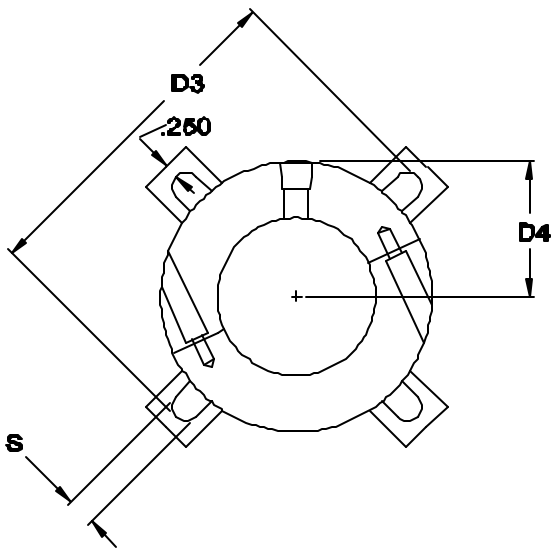

Direction of view is from the driver end of pump.

Suggested Environmental Controls

Piping Details



SINGLE CARTRIDGE SPLIT SEALS MODELS 9500

It is recommended that the seal cavity be vented through the pump's lantern ring connection located at top dead center available on some pump models. It is always recommended that a flush injection be utilized. The flush should be piped into the seal gland to ensure maximum efficiency.

PORT IDENTIFICATION: Flush ports provide flushing across seal faces into the process fluid.

PORT CONFIGURATION:

Two flush ports are provided for ease of piping to accommodate various equipment designs.

NOTE: See API plans listed below for specific piping plan to be used or as shown in "Suggested Environmental Controls" on page 8.

WHEN FLUSHING FROM A HIGHER PRESSURE OR EXTERNAL SOURCE (EX: API PLAN 11, 12, 21, 22, 23, 31, 32, 41, 86, 97, 99):

FLUSH PORT:

Port should ideally be located at 12 o'clock and piping be supplied to this flush port for all API Flush Plans.

WHEN FLUSHING TO A LOWER PRESSURE SOURCE (EX: API PLAN 13, 85, 98):

FLUSH PORT:

Port should ideally be located at 12 o'clock and piping be supplied to this flush port for all API Flush Plans.

WARNING: Take all necessary precautions and follow safety procedures before starting the equipment.

A flush is always recommended. Three types are commonly used:

API Plan 11

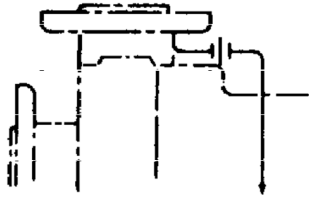

Plan 11
Recirculation from pump case through orifice and back to seal

A line is connected from the pump discharge to the seal gland. The pumped fluid used to flush the seal must be clean and at a temperature well below the product's vapor pressure at seal chamber temperature. In some cases where the product is near its initial boiling point at chamber pressure, the seal chamber pressure may be increased by installing a bushing in the throat of the chamber. This bushing will increase the seal chamber pressure and reduce damaging flashing and vaporization of the product at the seal faces.

API Plan 13

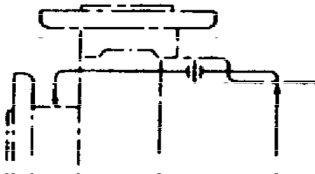

Plan 13
Recirculation from seal chamber through orifice and back to pump suction. Seal box pressure must be greater than vapor pressure of process fluid at pumping temperature.

A line is connected from the pump suction to the seal gland. This is used to reduce pressure in the seal chamber enabling the seal to run cooler and to recirculate liquid and solids away from the seal faces.

API Plan 32

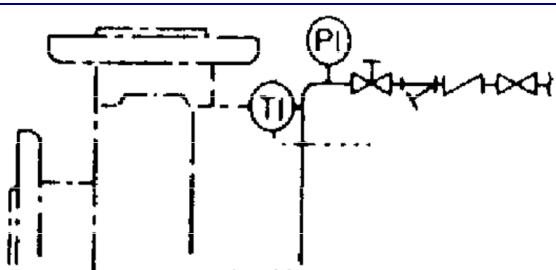

Plan 32
Injection to seal from external source of clean fluid into process fluid.

The seal is flushed from a clean, cool external source at a rate and temperature to maintain a proper environment for the seal. The flush must be sufficient to prevent the pumped fluid from entering the seal chamber. A close clearance bushing installed in the bottom of the seal chamber will reduce the flush required by increasing the velocity at the throat at a given flow.

WARNING:

Take all necessary precautions and follow safety procedures before starting the equipment.

